



OWNER'S OPERATING MANUAL

CRYSTAL
S E R I E S L

CR-32HD / CR-40HD

with **Widevision™**
Crystal Series™ LCD Displays



THE WORLD'S FINEST HOME THEATER PRODUCTS™

Table of Contents

One Year Limited Warranty	4
Introduction	7
Precautions	8
Control Panels	
CR-32HD and CR-40HD Front View	9
CR-32HD Rear View and Input Panel.....	10
CR-40HD Rear View and Input Panel.....	11
Remote Control	12
Connections	
Connecting an Antenna or Cable	13
Connecting to the Video or S-Video Input (INPUT1 or INPUT2)	13
Using the MONITOR OUT feature	14
Connecting to a DVD or DTV Set-Top Box INPUT (RCA or DVI)	14
Connecting to a PC	15
Setting the PC Properties	16
Connecting Headphones	16
Basic Operations	
Connecting the Power Cord and Switching the Display On/Off	17
Selecting a Source.....	17
Selecting an Aspect Ratio	18
Selecting Picture Adjust	19
Selecting Audio.....	20
Selecting Channel (For CR-32HD only)	20
Selecting Timer	21
Setup	
OSD Language.....	22
PC Mode Adjust	22
Caption.....	23
Parental Control.....	23
Letterbox Mode	23
Input Selection.....	24
Monitor Out	24
Overscan	24



ISF Calibration (Service)

Picture Adjust 25
White Balance 25
Blue Enable 26
DNR 26
Gamma 26
Baud Rate 26
Command ACK 26
Factory Reset 26
Splash Duration 26

Picture in Picture (PIP)

Displaying the Picture in Picture (PIP) 27
Changing the PIP Position 28
Changing the PIP Size 28
Selecting the Image Size in the PIP 28
Selecting the Image Mode in the PIP 28
Swapping the Main & Sub-Picture 29
Swapping the Main & Sub-Sound 29
Changing the PIP Aspect Ratio 30

Stereo Sound / SAP

Listening to Stereo Sound / SAP 31

RS-232 Configurations

RS-232C Configurations 32
Serial Protocol 33

Signals Supported

Standard Display Mode 35

Pin Configuration (PC/DVI)

PC Input Connector (D-Sub 15Pin) 36
DVI-D Connector 36

Troubleshooting

For Display Panel 37
For Monitor 38

Specifications 39

Dimensions 40

One Year Limited Warranty

Congratulations on your purchase of Runco's latest video product and welcome to the Runco family! We believe Runco produces "The World's Finest Home Theater Products". With proper installation, setup and care, you should enjoy many years of unparalleled video performance.

This is a LIMITED WARRANTY as defined in the Magnuson-Moss Warranty Act. Please read it carefully and retain it with your other important documents.

WHAT IS COVERED UNDER THE TERMS OF THIS LIMITED WARRANTY:

SERVICE LABOR: Runco will pay for service labor by a Runco Authorized Service Center when needed as a result of a manufacturing defect for a period of one (1) year from the effective date of delivery to the end user.

PARTS: Runco will provide new or rebuilt replacement parts for the parts that fail due to defects in materials or workmanship for a period of one (1) year from the effective date of delivery to the end user. Such replacement parts are then subsequently warranted for the remaining portion (if any) of the original warranty period.

WHAT IS NOT COVERED UNDER THE TERMS OF THIS LIMITED WARRANTY:

Image retention on LCD display panels are specifically excluded from coverage under this Limited Warranty. Image retention or staining of an image is the result of misuse of the product and therefore cannot be repaired under the terms of this Limited Warranty.

Normal viewing material such as television/satellite broadcasts, videotape or DVDs (not put into pause for extended periods of time) will not cause damage to your display under normal conditions. Many DVD players are also equipped with screen savers for this reason.

TO AVOID IMAGE RETENTION (Burn-in):

Please ensure that still images are not left on your LCD display panel. Also ensure that images displayed in the 4:3 aspect ratio mode (black or gray stripes, but no picture information is present on the left and right edges of the screen) are used as infrequently as possible. This will prevent permanent image burns on your LCD display panel, which can be seen permanently under certain conditions once burn-in has occurred.

The types of images to avoid include video games, still images and computer screens with stationary tool bars and icons. (This is why computers are equipped with screen savers – to prevent still images from burning into the monitor's phosphors after being displayed continuously for an extended period of time).

This Limited Warranty only covers failure due to defects in materials and workmanship that occur during normal use and does not cover normal maintenance. This Limited Warranty does not cover cabinets or any appearance items; failure resulting from accident, misuse, abuse, neglect, mishandling, misapplication, faulty or improper installation or setup adjustments; improper maintenance, alteration, improper use of any input signal; damage due to lightning or power line surges, spikes and brownouts; damage that occurs during shipping or transit; or damage that is attributed to acts of God. In the case of remote control units, damage resulting from leaking, old, damaged or improper batteries is also excluded from coverage under this Limited Warranty.

CAUTION: THIS LIMITED WARRANTY ONLY COVERS RUNCO PRODUCTS PURCHASED FROM RUNCO AUTHORIZED DEALERS. ALL OTHER PRODUCTS ARE SPECIFICALLY EXCLUDED FROM COVERAGE UNDER THIS LIMITED WARRANTY. MOREOVER, DAMAGE RESULTING DIRECTLY OR INDIRECTLY FROM IMPROPER INSTALLATION OR SETUP IS SPECIFICALLY EXCLUDED FROM COVERAGE UNDER THIS LIMITED WARRANTY.

RIGHTS, LIMITS AND EXCLUSIONS:

Runco limits its obligations under any implied warranties under state laws to a period not to exceed the warranty period. There are no express warranties. Runco also excludes any obligation on its part for incidental or consequential damages related to the failure of this product to function properly. Some states do not allow limitations on how long an implied warranty lasts, and some states do not allow the exclusion or limitation of incidental or consequential damages. So the above limitations or exclusions may not apply to you. This warranty gives you specific legal rights, and you may also have other rights that vary from state to state.

EFFECTIVE WARRANTY DATE:

This warranty begins on the effective date of delivery to the end user. For your convenience, keep the original bill of sale as evidence of the purchase date.

IMPORTANT - WARRANTY REGISTRATION:

Please fill out and mail your warranty registration card. It is imperative that Runco knows how to reach you promptly if we should discover a safety problem or product update for which you must be notified.

CONTACT A RUNCO AUTHORIZED SERVICE CENTER TO OBTAIN SERVICE:

Repairs made under the terms of this Limited Warranty covering your Runco video product will be performed at the location of the product, during usual working hours, providing location of product is within normal operating distance from a Runco Authorized Service Center. In some instances it may be necessary for the product to be returned to the Runco factory for repairs. If, solely in Runco's judgment, location of product to be repaired is beyond normal operating distance of the closest Runco Authorized Service Center, or the repair requires the unit be returned to the Runco factory, it is the owner's responsibility to arrange for shipment of the product for repair. These arrangements must be made through the selling Runco Dealer. If this is not possible, contact Runco directly for a Return Authorization number and shipping instructions. Runco will return product transportation prepaid in the United States, unless no product defect is discovered. In that instance, shipping costs will be the responsibility of the owner.

ADDITIONAL INFORMATION:

To locate the name and address of the nearest Runco Authorized Service Center, or for additional information about this Limited Warranty, please call or write:

RUNCO INTERNATIONAL, INC.

Attn: Customer Service Department

2900 Faber Street

Union City, CA 94587

Ph: (510) 324-7777

Fax: (510) 324-9300

Toll Free: (800) 23-RUNCO

RUNCO VIDEO PRODUCT INFORMATION

RETAIN THIS INFORMATION FOR YOUR RECORDS

Model Purchased

Date

Serial Number

Runco Authorized Dealer Name

Address

City

State/Province

Postal Code

Phone

Fax

Introduction

Runco presents the high performance Crystal Series™ LCD displays, perfect for those who demand our award-winning flat panel performance in more intimate sizes than we offer with our larger plasma monitors.

The new Crystal Series™ high definition capable LCD displays offer common features and performance in popular 26, 32 and 40-inch sizes, suitable for close-in viewing where picture quality remains a high priority, but larger displays cannot be accommodated.

The Crystal Series™ models incorporate the superb Vivix™ digital video processing that produces outstanding picture quality with a wide range of both standard and high definition source material.

In addition, these handsome, gloss black televisions are engineered with ISF™ calibration standards in every model for the purest video performance. The CR-32HD also features an advanced, 185 channel cable-ready NTSC stereo tuner offering PIP, POP, closed captioning, Parental Control (V-Chip) functionality and multi-language support. Both the CR-32HD and CR-40HD include integrated stereo audio systems incorporating surround sound technology with 2-way speakers and generous power amplification.

The advanced TFT active matrix LCD display panels offer 1366 x 768 resolution on both models and include Runco's discrete aspect ratio control with VirtualWide™ mode to fill the 16:9 screen with standard 4:3 images without loss of picture quality. Also included are discrete source, aspect ratio and power selection and an RS-232 interface for whole house or automated control system integration.

The Crystal Series™ CR-32HD and CR-40HD are multimedia ready, with simple computer connections making gaming, internet browsing and other computer activities quick and easy.

Precautions



This symbol is intended to alert the user to the presence of uninsulated “dangerous voltage” within the product’s enclosure that may be of sufficient magnitude to constitute a risk of electric shock to persons.



This symbol is intended to alert the user to the presence of important operating and maintenance (servicing) instructions in the literature accompanying the appliance.

CAUTION

To turn off main power, be sure to remove the plugs from power outlets. The power outlet socket should be installed as near to the equipment as possible, and should be easily accessible.

WARNING

TO PREVENT FIRE OR SHOCK HAZARDS, DO NOT EXPOSE THIS UNIT TO RAIN OR MOISTURE. ALSO DO NOT USE THIS UNIT’S POLARIZED PLUG WITH AN EXTENSION CORD RECEPTACLE OR OTHER OUTLETS, UNLESS THE PRONGS CAN BE FULLY INSERTED REFRAIN FROM OPENING THE CABINET AS THERE ARE HIGH-VOLTAGE COMPONENTS INSIDE. REFER SERVICING TO QUALIFIED SERVICE PERSONNEL.

WARNING

This equipment has been tested and found to comply with the limits for a Class ‘B’ digital device, pursuant to Part 15 of the FCC Rules. These limits are designed to provide reasonable protection against harmful interference when the equipment is operated in a commercial environment. This equipment generates, uses, and can radiate radio frequency energy and, if not installed and used in accordance with the Installation Manual, may cause harmful interference to radio communications. Operation of this equipment in a residential area may cause harmful interference, in which case, the user will be required to correct the interference at his own expense.

DOC compliance Notice

This Class B digital apparatus meets all requirements of the Canadian Interference-Causing Equipment Regulations.

Please read and follow the safety precautions listed below to ensure the equipment is free from damage, and to ensure that no injury will occur as a result of improper use.

- Do not insert any object, especially metal or liquids, into the LCD display.
- Do not place any objects containing water or any other liquid on top of the LCD display.
- Do not place the units in direct sunlight, near heaters or in extremely dusty or humid locations.
- Do not install this system outdoors or otherwise exposed to the elements.
- Do not place heavy objects on top of the LCD display.
- If the power cord is damaged or frayed in any way, electrical shock and/or fire may result. Do not place objects on the power cord, and keep the cord away from heat-emitting devices. Should the power cord become damaged in any way, please contact your Runco Dealer for a replacement cord.
- Do not remove the cover of the LCD display for any reason. If any problems arise with the unit, please contact a Runco Dealer or Runco International for service. Removing the covers will void the warranty.

Control Panels

**CR-32HD and CR-40HD
Front View**

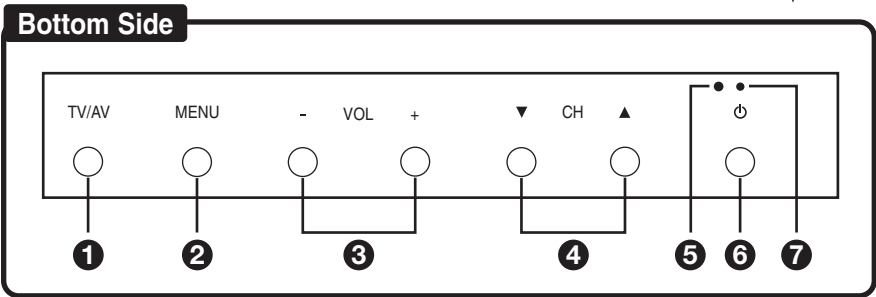
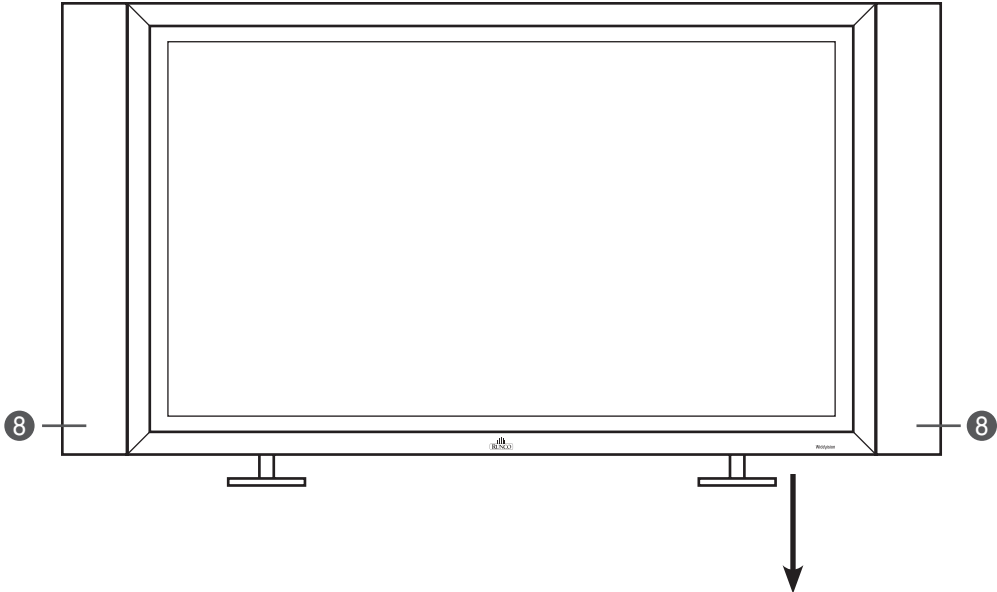

- 1 TV/AV Button (Input Source Selection)
- 2 MENU Selection Button
- 3 Volume Adjustment Buttons
- 4 Channel Selection Buttons
- 5 Remote Control Sensor
- 6 Power Button
- 7 Power Indicator
- 8 Speakers

Power Indicator Status

Indicator	Status
Red	Stand-by
Green	Power on
Green blinking	Remote control

CR-32HD Rear View and Input Panel

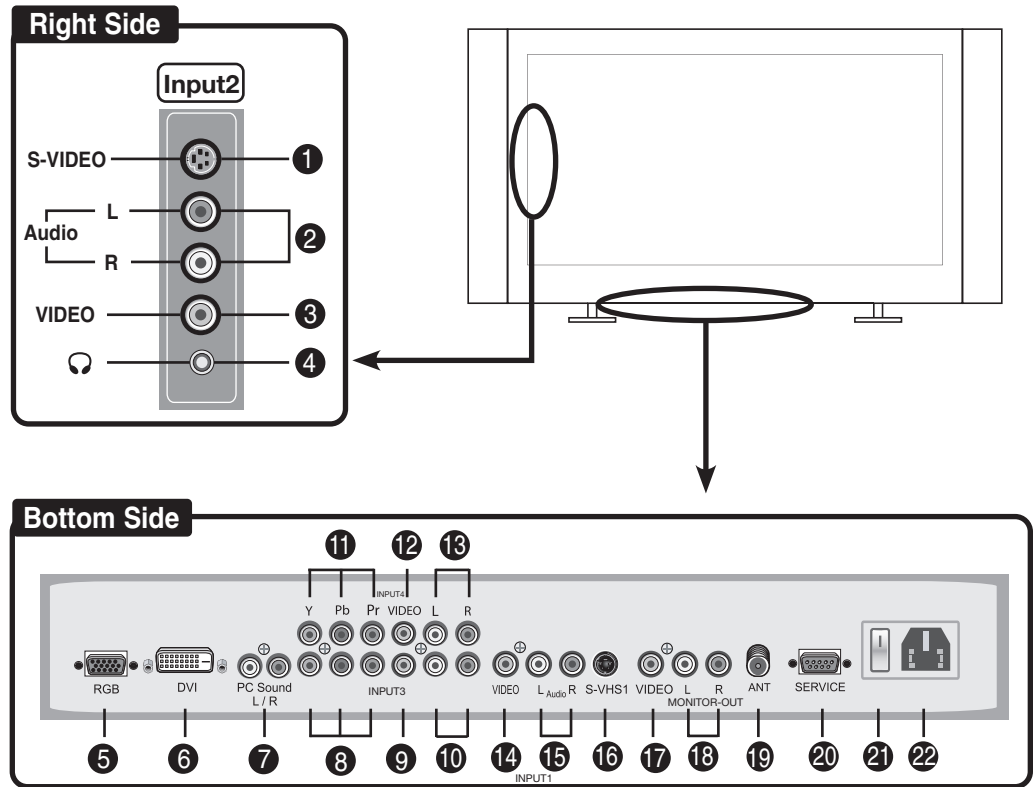

- | | |
|--|---|
| 1 INPUT2 S-Video Input | 12 INPUT4 Video Input (VIDEO) |
| 2 INPUT2 Audio Input | 13 INPUT4 Audio Input (DTV/DVD) |
| 3 INPUT2 Video Input | 14 INPUT1 Video Input |
| 4 Headphone Jack | 15 INPUT1 Audio Input |
| 5 RGB Input Connector (PC) | 16 INPUT1 S-Video Input |
| 6 DVI-D Input Connector (PC) | 17 MONITOR-OUT (Video) |
| 7 Audio Input (PC) | 18 MONITOR-OUT (Audio) |
| 8 INPUT3 Video Input (DTV/DVD) | 19 Antenna/cable Input Jack |
| 9 INPUT3 Video Input (VIDEO) | 20 SERVICE Port (For RS-232 Control) |
| 10 INPUT3 Audio Input (DTV/DVD) | 21 Power Switch (Main) |
| 11 INPUT4 Video Input (DTV/DVD) | 22 Power Input |

CR-40HD Rear View and Input Panel

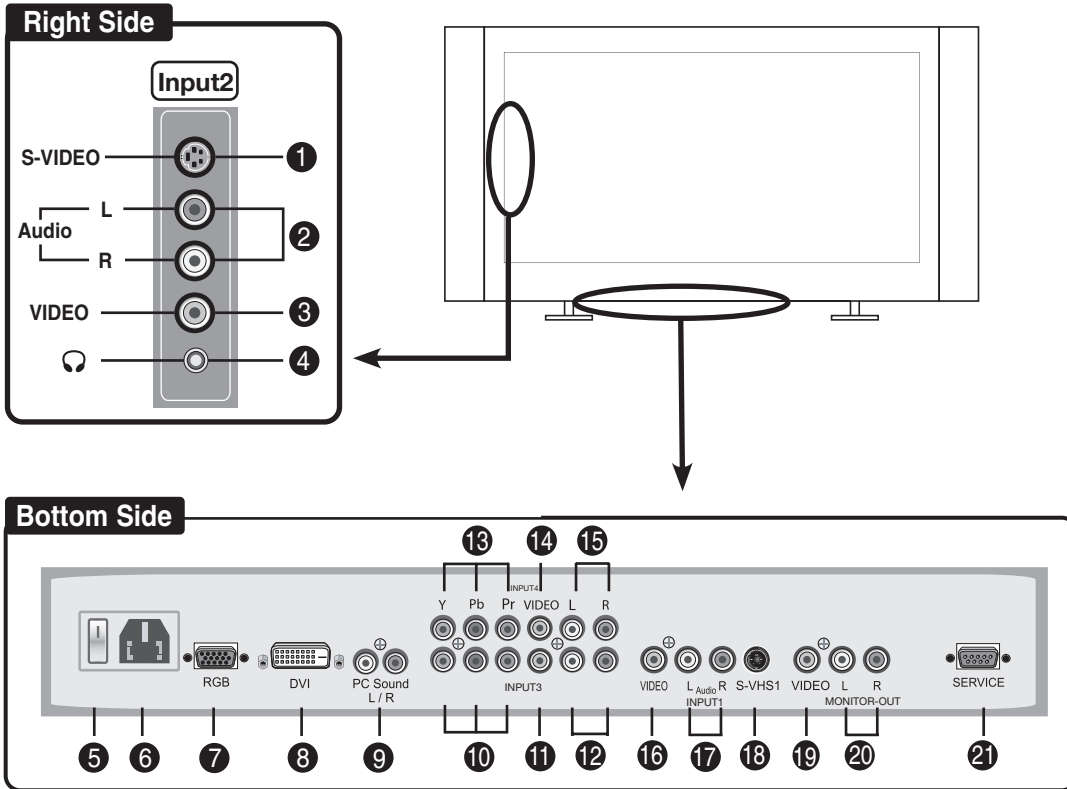

- | | |
|---------------------------------|--------------------------------------|
| 1 INPUT2 S-Video Input | 12 INPUT3 Audio Input (DTV/DVD) |
| 2 INPUT2 Audio Input | 13 INPUT4 Video Input (DTV/DVD) |
| 3 INPUT2 Video Input | 14 INPUT4 Video Input (VIDEO) |
| 4 Headphone Jack | 15 INPUT4 Audio Input (DTV/DVD) |
| 5 Power Switch (Main) | 16 INPUT1 Video Input |
| 6 Power Input | 17 INPUT1 Audio Input |
| 7 RGB Input Connector (PC) | 18 INPUT1 S-Video Input |
| 8 DVI Input Connector (PC) | 19 MONITOR-OUT (Video) |
| 9 Audio Input (PC) | 20 MONITOR-OUT (Audio) |
| 10 INPUT3 Video Input (DTV/DVD) | 21 SERVICE Port (For RS-232 Control) |
| 11 INPUT3 Video Input (VIDEO) | |

Remote Control

OFF Button
To turn off the unit.
ON Button
Hold down this button for one second to turn on the unit.

NUMERIC Buttons
To select channel and to enter pass codes.
The "100" button is to select channels over 100.

DISCRETE SOURCE SELECTION

- **INPUT 1**
For Composite video or S-Video signals.
- **INPUT 2**
For Composite video or S-Video signals.
- **INPUT 3**
For Component video or composite video signals.
- **INPUT 4**
For Component video or composite video signals.
- **DVI**
For Digital video input signals.
- **RGB HD**
For DTV RGBHV or PC signals.
- **TV**
For ant/cable signals. (CR-32HD only)

ARROW Buttons
To select the menu or to make various adjustments.
ENTER Button
To enter the setting of items in the menu.

MENU Button
To display the OSD menu.

PIP FUNCTION Buttons
See page 27-30 for Operation instructions.

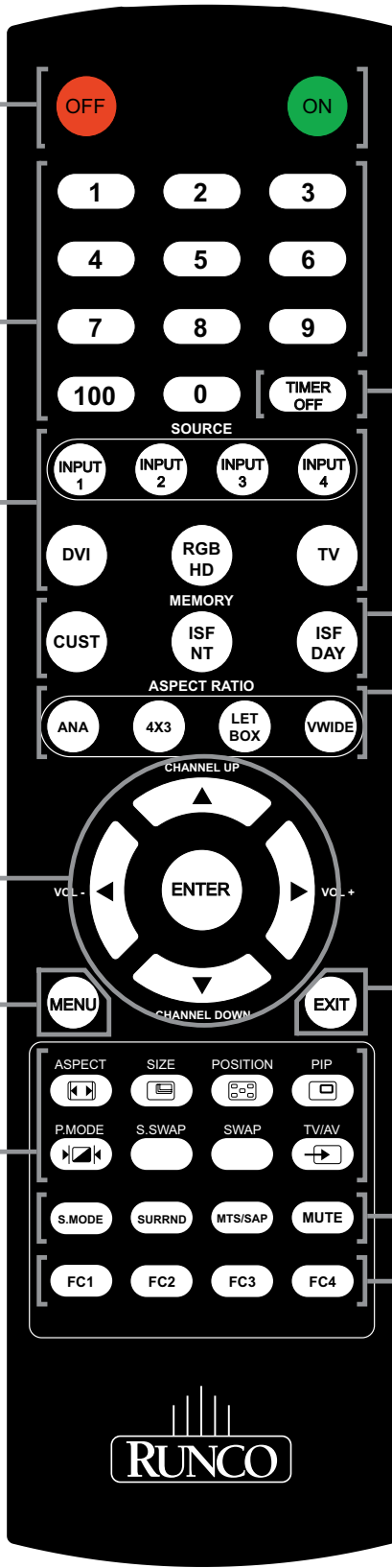

TIMER OFF Button
To access sleep timer.

MEMORY Buttons
To recall video memory sequentially.

ASPECT RATIO Buttons

- **ANA**
For Anamorphic 16:9 or widescreen enhanced DVD.
- **4X3**
For standard video format.
- **LETTERBOX**
Image in letterbox format is enlarged to fit 16:9 full screen display and the upper/lower portion are "blanked off".
- **VIRTUALWIDE**
4:3 image is nonlinearly stretched in a horizontal direction to fit 16:9 full screen display.

EXIT Button
To clear the OSD menu.

SOUND SELECTION Buttons
See page 20, 31 for menu diagram.

FAVORITE CHANNEL Buttons
See page 21 for menu diagram.

- Note:**
- Makes sure there are no objects between the remote control and its sensor.
 - Don't place the remote control near a heater or in damp place.
 - A strong blow to the remote control may cause it not to operate.

Connections

To view television channels, a signal must be input from either an outdoor antenna or a cable television system.

1. Connect the antenna or input cable to the 75 Ω coaxial input on the rear of the display.
2. If you are using an indoor antenna, you may need to turn it when tuning your television until you receive a clear picture.

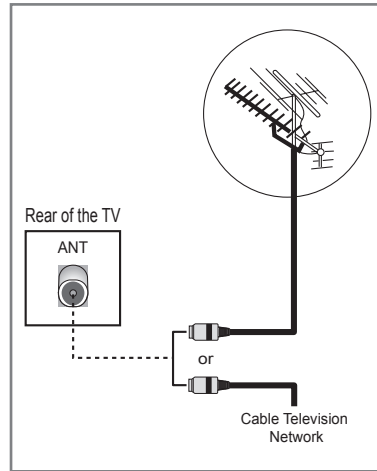

Connecting an Antenna or Cable (Not applicable on the CR-40HD)

Rear of the display

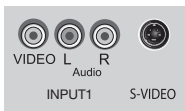

(A) For Video (RCA) Input

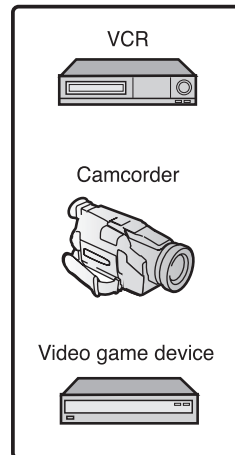

Connecting to the Video or S-Video Input (INPUT1 or INPUT2)

Right side of the display

Input2



(B) For S-Video Input



(A) For Video Input

1. Connect the RCA cable to the input jacks (video+ audio L/R of Input1 or Input2) on the display and output jacks on the external equipment such as a VCR, camcorder and some video game devices.

(B) For S-Video Input

1. Connect the S-Video/RCA (audio L/R of Input1 or Input2) cable to the input jacks on the display and output jacks on the external equipment such as a VCR, camcorder and some video game devices.
2. If the external equipment has mono audio output, connect it only to left jack of the Audio Input/Output.

Using the MONITOR OUT feature

You can choose the Main or PIP screen to record. Refer to page 24 for more information.

Rear of the display

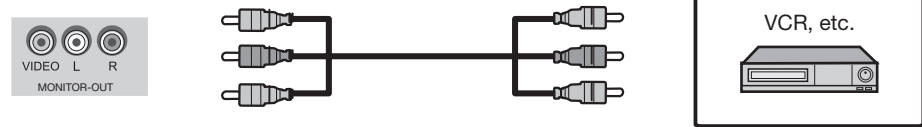

- Your display has a monitor out feature which can be used by a second VCR, or other auxiliary equipment.

To do this, connect your second VCR as follows:

1. Connect a set of audio cables between the AUDIO OUT jacks on the display and the AUDIO IN jacks on the VCR, or auxiliary equipment.
2. Connect a video cable between the VIDEO OUT jack on the display and the VIDEO IN jack on the VCR, or auxiliary equipment.

Connecting to a DVD or DTV Set-Top Box INPUT (RCA or DVI)

Rear of the display

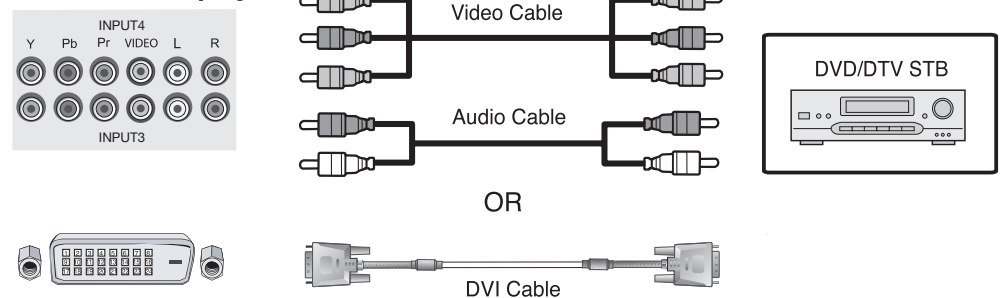

1. Connect the video cables to the Y, Pb, Pr input jacks (INPUT3 or INPUT4) on the display and the Y, Pb, Pr output jacks on the DVD or DTV Set-Top Box.
2. Connect the audio cables to the Audio L/R input jacks (INPUT3 or INPUT4) on the display and the Audio output jacks on the DVD or DTV Set-Top Box.

1. Connect the DVI cables to the DVI input jacks (DVI) on the display and the DVI output jacks on the DVD or DTV Set-Top Box.
2. Connect the audio cables to the Audio L/R input jacks on the display and the Audio output jacks on the DVD or DTV Set-Top Box.

To use the display as a PC Monitor

1. Turn the PC on.
2. Depending on the connection, press the DVI or RGB HD button on the remote control.
3. Set up the PC Properties. (See page 16)
4. Adjust the screen in PC Mode. (See page 22)

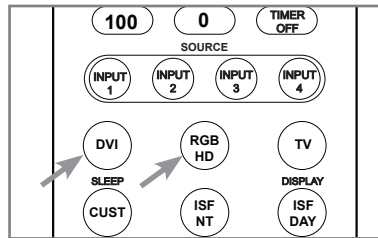

Connecting to a PC

RGB

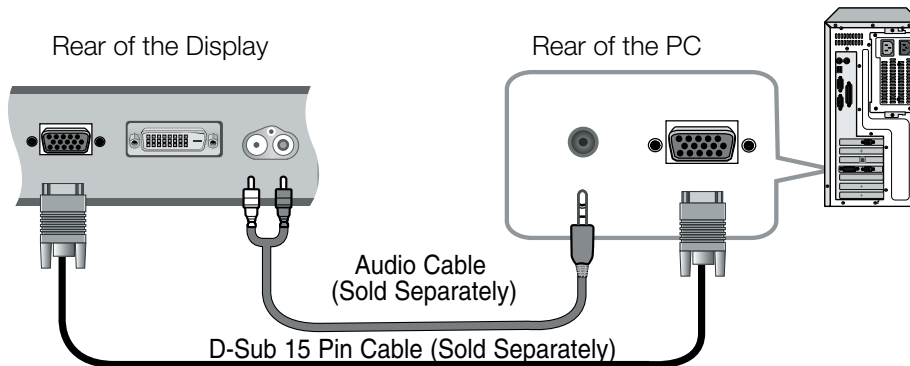

◆ Connect the D-Sub 15 Pin Cable to the **RGB** Input port on the TV and output port on the Rear of the PC.

DVI-D

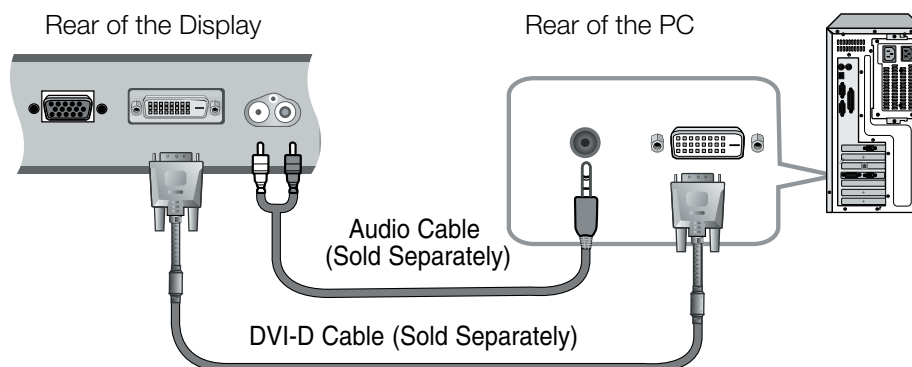

◆ Connect the DVI-D Cable to the **DVI** Input port on the TV and output port on the Rear of the PC.

Setting the PC Properties

1. First, click on Settings on the Windows Start menu and click on “Control Panel”.
2. Double click on the Display icon.
3. Click on the Settings tab on the display dialog-box.
4. Adjust the resolution to 1024x768 pixels.
5. Click the Advanced button and click the Monitor tab on the dialog-box. Set the vertical-frequency to 60Hz and then click the OK button.

Note:

- Maximum resolution depends on the Video Card.
- Maximum supported resolution is 1024 x 768 @ 75Hz. You can get the best picture at 1024 x 768 @ 60Hz.
- There are 16,770,000 supported colors.

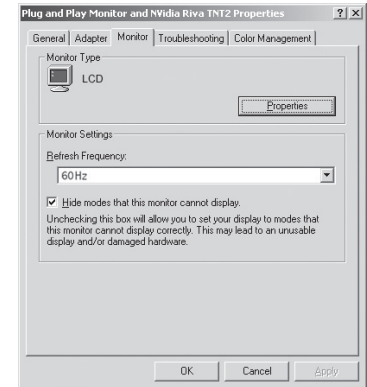
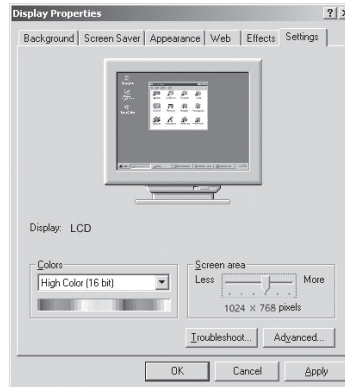
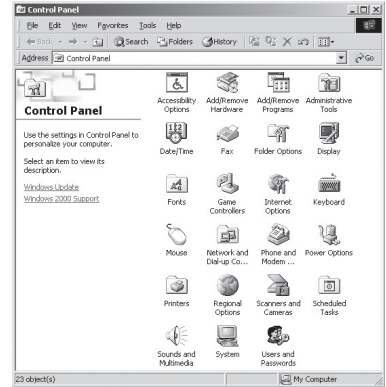

Connecting Headphones

Right side of the display

Input2



You can connect a set of headphones to your display if you wish to watch a program without disturbing other people.

1. Plug a set of headphones into the 3.5mm mini-jack socket on the right side of your display. Sound will then be routed through the headphones.

Note: Headphones are not included.

Basic Operations

1. Connect the power cord for your display to the power input on the back of your display.
2. Plug the power cord for the display into a nearby outlet.
3. Press the **POWER** (ON) button on the remote control or the POWER button on the display panel.
4. To switch your display off, press the **POWER** (OFF) button on the remote control or the POWER button on the display panel.

Connecting the Power Cord and Switching the Display On / Off

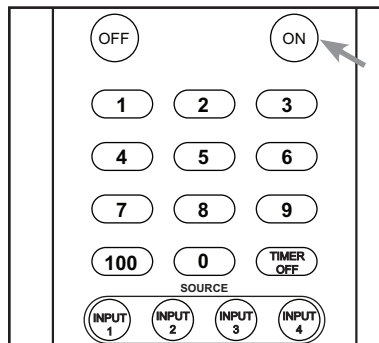

1. Press the MENU button on the remote control.
2. Press the ▲ ▼ buttons to select **Source** and then press the ENTER or ► button.
3. Select the appropriate Source by pressing the ▲ ▼ buttons and then press the ENTER or ► button.
 - You can select **TV, Input 1, Input 2, Input 3, Input 4, DVI or RGB.**
4. Press the MENU button to return to the previous menu.

Selecting a Source

OR

You can also select the Source directly from the remote control using discrete source buttons.

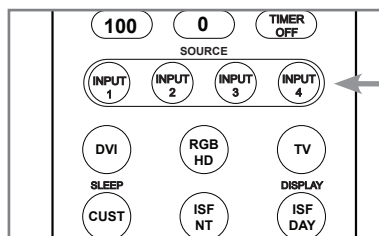
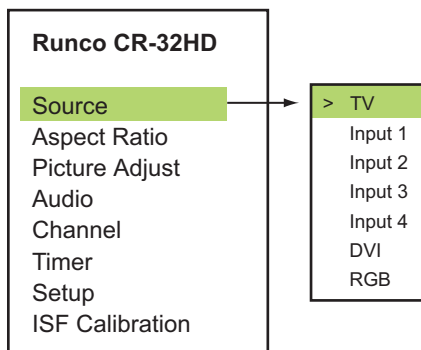

Selecting an Aspect Ratio

1. Press the MENU button on the remote control.
2. Press the ▲ ▼ buttons to select **Aspect Ratio** and then press the ENTER or ► button.
3. Select the appropriate **Aspect Ratio** by pressing the ▲ ▼ buttons and then press the ENTER or ► button.
 - You can select **Anamorphic, Standard, Letterbox** or **VirtualWide**.
4. Press the MENU button to return to the previous menu.

OR

You can also select the Aspect Ratio directly from the remote control using discrete Aspect Ratio buttons.

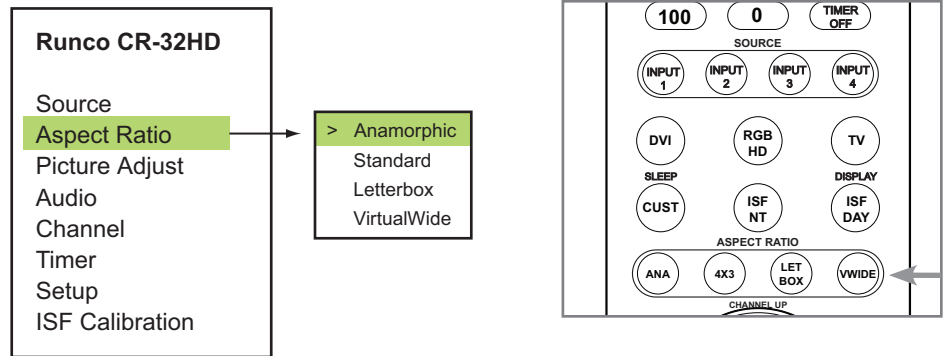

ANAMORPHIC mode

The Anamorphic aspect ratio expands the image in the horizontal direction. The image is compressed vertically, but with anamorphic software the image will appear properly proportioned. This is best suited for use with 16:9 DVD's and HDTV.



STANDARD 4:3 mode

The image is displayed at a standard 4:3 aspect ratio. The input signal will be scaled to fit in the center of the 16:9 screen.



LETTERBOX mode

The image in the Letterbox mode will be zoomed in, and the top and bottom portion 'blanked off.' This ratio is best suited for LaserDisc movies or non-anamorphic DVD's.



VIRTUALWIDE mode

The VirtualWide mode is an aspect ratio is designed to fill the 16:9 screen with a 4:3 image. The center of the picture is not stretched, and it gradually stretches on the sides reaching the most extreme stretch at the far edges of the picture (non-linear scaling). In addition, we apply a very slight vertical stretch uniformly (no graduation) which results in a very small amount of cropping of the top and bottom of the image area. Thus a 4:3 image is transformed into a 16:9 image with minimal distortion.



1. Press the MENU button on the remote control.
2. Press the ▲▼ button to select PICTURE ADJUST and then press the ENTER or ► button.
3. Press the ▲▼ button to select **Brightness, Contrast, Color, Tint, Sharpness, Color Temp., Backlight, Save Settings** or **Restore Settings**.
4. Press the MENU button to return to the previous menu.

Selecting Picture Adjust

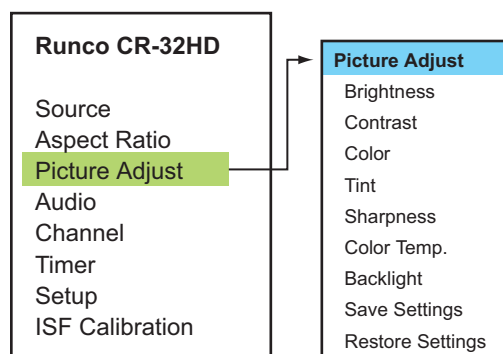

Note:

Each input and scan rate has their own picture memories. Make sure you store your picture settings before you switch to another input or scan rate.

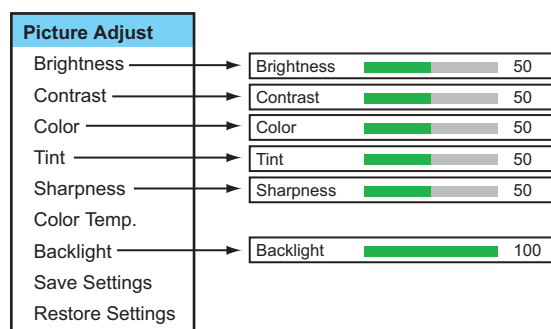

Color Temp.

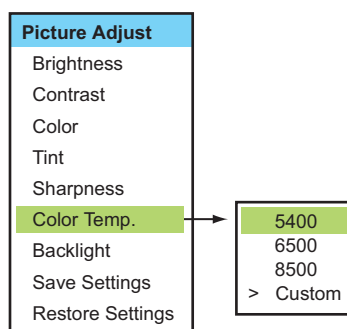

Note:

Temperature 5400, 6500, 8500 are global selections and are not adjustable. If Color Temp. requires calibration, you must select Custom and make adjustments in the ISF Menu under White Balance. (See page 25)

Save Settings

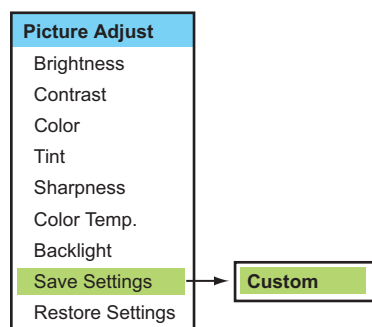

Restore Settings

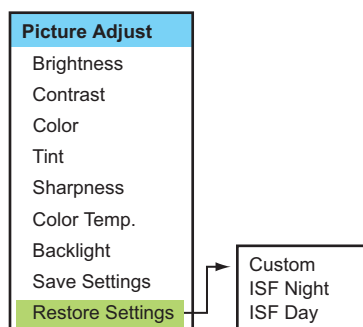

Selecting Audio

1. Press the MENU button on the remote control.
2. Press the ▲ ▼ buttons to select **Audio** and then press the ENTER or ► button.
3. Press the ▲ ▼ buttons to select **Balance, Equalizer** or **Surround**.
4. Press the MENU button to return to the previous menu.

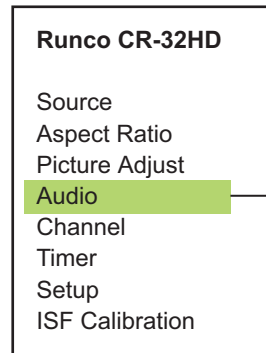

Balance

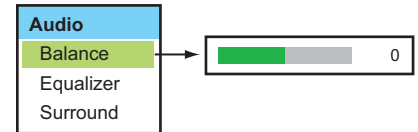

1. Adjust the Sound Balance with the ◀ ▶ buttons.

Equalizer

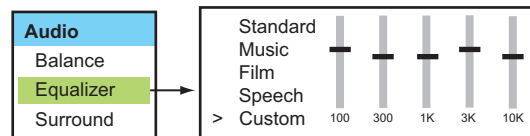

Surround

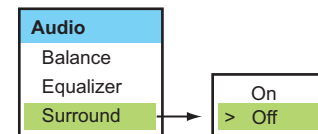

Note:

When Surround is selected, the Equalizer feature is automatically "grayed out."

1. Press the ▲ ▼ buttons to select **Equalizer** and then press the ENTER or ► button.
2. Press the ▲ ▼ buttons to select **Standard, Music, Film, Speech** and **Custom** on the remote control or the  to toggle between the selection.
3. Press the ▲ ▼ buttons to select **Custom** and then press the ENTER or ► button. Press the ◀ ▶ buttons to select the frequency. The frequency range will be selected as the following order: **100 → 300 → 1K → 3K → 10K**. Press the ▲ ▼ buttons to make the adjustments.

Selecting Channel

(For the CR-32HD only)

1. Press the MENU button on the remote control.
2. Press the ▲ ▼ buttons to select **Channel** and then press the ENTER or ► button.
3. Press the ▲ ▼ buttons to select **TV/CATV, Auto Tuning, Add/Erase, Fine Tune** or **Favorite Channel**.
4. Press the MENU button to return to the previous menu.

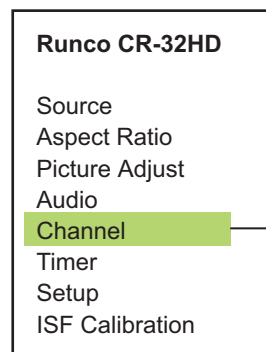

TV / CATV

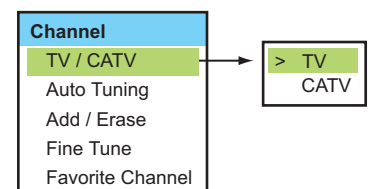

Auto Tuning

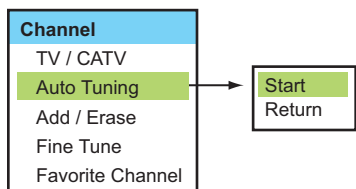

Add /Erase

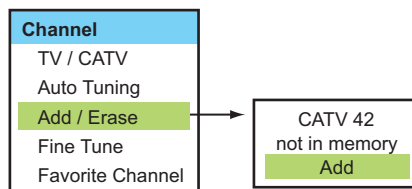

Fine Tune

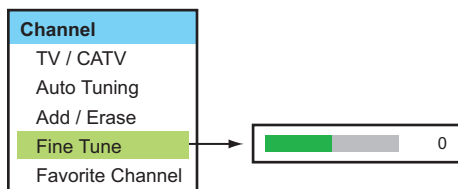

Favorite Channel

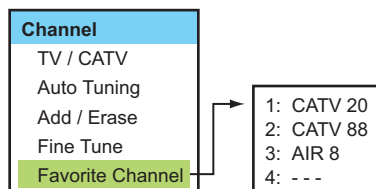

1. Press the MENU button on the remote control.
2. Press the ▲ ▼ buttons to select **Timer** and then press the ENTER or ► button.
3. Press the ▲ ▼ buttons to select **Timer, On Timer, Off Timer** or **Sleep Timer**.
4. Press the MENU button to return to the previous menu.

Selecting Timer

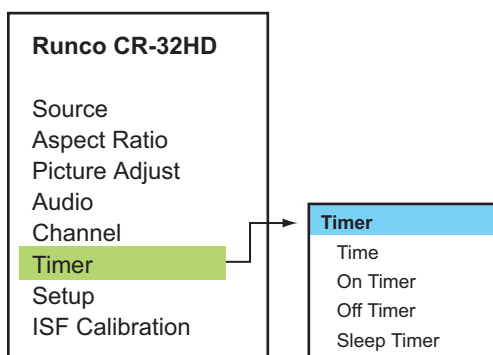

Timer

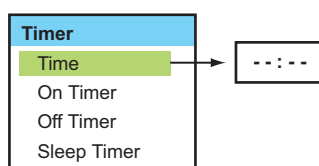

1. Press the ▲ ▼ buttons to select the hour or minutes.
2. Press the ◀ ▶ buttons to adjust the hour and minutes.
3. Press the Menu button to exit.

On Timer

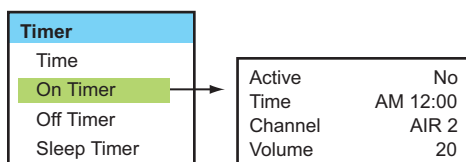

1. Press the ▲ ▼ buttons to highlight **On Timer** and press the Enter button.
2. Press the ▲ ▼ buttons to make the selection.
3. Press the ◀ ▶ buttons to make the adjustments.

Off Timer

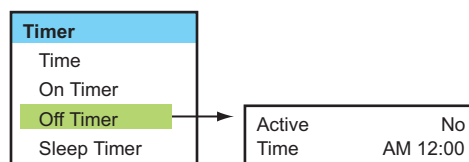

1. Press the ▲ ▼ buttons to highlight **Off Timer** and press the Enter button.
2. Press the ▲ ▼ buttons to make the selection.
3. Press the ◀ ▶ buttons to make the adjustments.

Sleep Timer

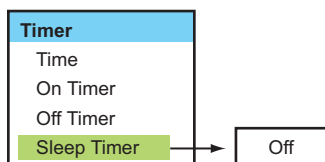

1. Press the ▲ ▼ buttons to highlight **Sleep Timer** and press the Enter button.
2. Press the ◀ ▶ buttons to select the desired minutes. (Maximum Sleep Timer is 3 hours.)

Setup

1. Press the MENU button on the remote control.
2. Press the ▲▼ buttons to select **Setup** and then press the ENTER or ► button.
3. Press the ▲▼ buttons to select **OSD Language, PC Adjust, Caption, Parental Control, Letterbox Mode, Input Selection, Monitor Out** or **Overscan**.
4. Press the MENU button to return to the previous menu.

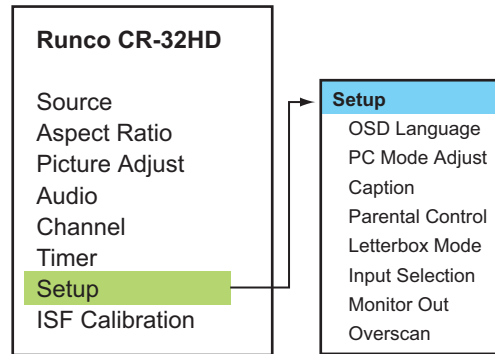

OSD Language

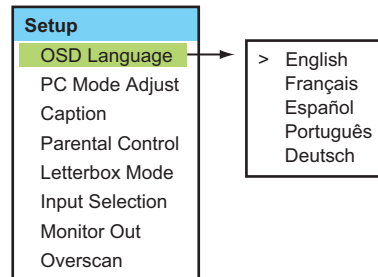

PC Mode Adjust

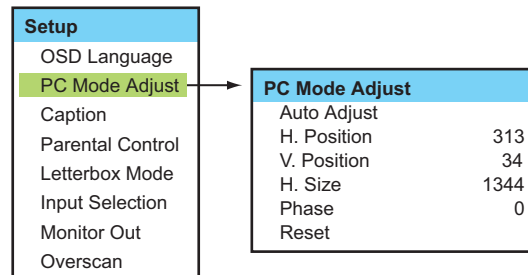

Note:

PC Mode Adjust active only through RGB input with VESA computer standards.

1. Press the ▲▼ buttons to select **PC Mode Adjust** and then press the ENTER or ► button.
2. Press the ▲▼ buttons to make the selection.
3. Press the ◀▶ buttons to make the adjustments.
 For best results, select 1024 x 768 from your computer output.

Caption

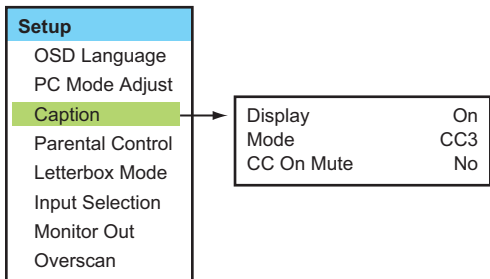

1. Press the ▲ ▼ buttons to select **Caption** and then press the ENTER or ► button.
2. Press the ▲ ▼ buttons to make the selection.
3. Press the ◀ ▶ buttons to make the adjustments.

You can select these options in the following order:

CC1 → CC2 → CC3 → CC4 → Text1 → Text2 → Text3 → Text4

Parental Control

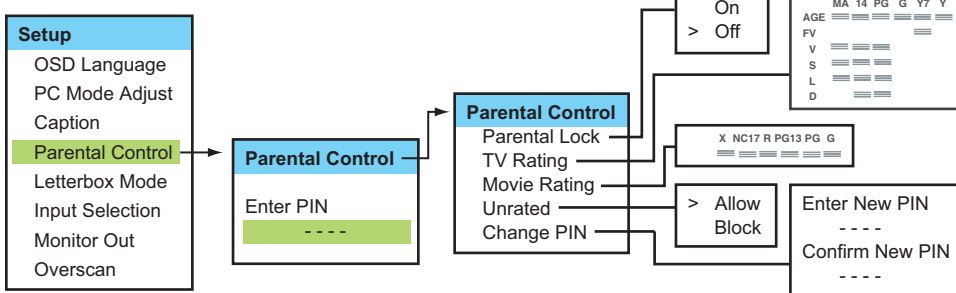

1. Press the ▲ ▼ buttons to select **Parental Control** and then press the ENTER or ► button.
2. Enter your 4-digit PIN number to access the Parental options. The default for the new LCD display is "0000".
3. Press the ▲ ▼ buttons to select **Parental Lock**, then press the Enter button to turn On or Off.
4. Press the ▲ ▼ buttons to select **TV Rating** and **Movie Rating**. Use the ◀ ▶ buttons to lock the option and the ▲ ▼ buttons to make the selection.
5. Press the ▲ ▼ buttons to select **Unrated** and press the Enter button. Use the ▲ ▼ buttons to make your selection and press the Enter button to confirm your selection.
6. Press the ▲ ▼ buttons to select **Change PIN** and press the Enter button. Enter your new 4-digit PIN number and enter a second time to confirm your new PIN number.

Letterbox Mode

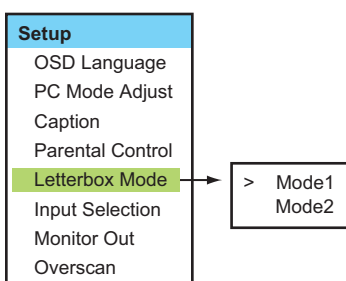

1. Press the ▲ ▼ buttons to select **Letterbox Mode** and then press the ENTER or ► button.
2. Highlight **Mode1** or **Mode2** and press the Enter button. An arrow will indicate the current selected mode.

Mode1: Standard Letterbox
Mode2: 2.35 Fill

Input Selection

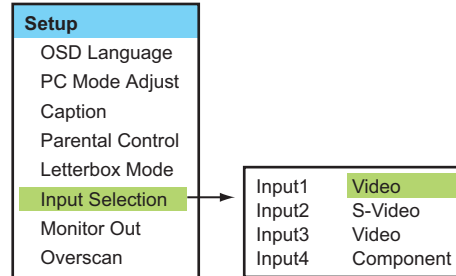

1. Press the ▲ ▼ buttons to select **Input Selection** and then press the ENTER or ► button.
2. Press the ▲ ▼ buttons to highlight **Input1, Input2, Input3 or Input4** and press the Enter button.
3. Press the ► button to toggle the selection.

Input1 and **Input2** can be assigned for S-Video or Video (Composite)
Input3 and **Input4** can be assigned for Component or Video (Composite)

Monitor Out

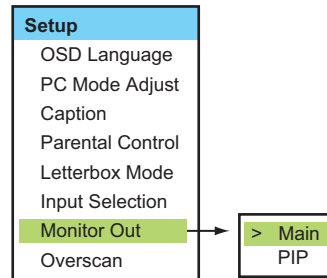

1. Press the ▲ ▼ buttons to select **Monitor Out** and then press the ENTER or ► button.
2. Press the ▲ ▼ buttons to highlight **Main** or **PIP** and then press the Enter button. An arrow will indicate the selected window.

Overscan

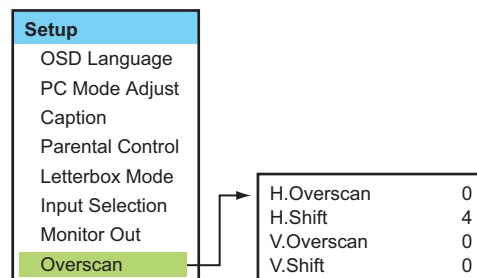

1. Press the ▲ ▼ buttons to select **Overscan** and then press the ENTER or ► button.
2. Press the ▲ ▼ buttons to highlight **H.Overscan, H.Shift, V.Overscan or V.Shift** and then press the Enter button.

ISF Calibration (Service)

1. Press the MENU button on the remote control.
2. Press the ▲ ▼ buttons to select **ISF Calibration** and then press the ENTER or ► button.
3. Press the ▲ ▼ buttons to select **Picture Adjust, White Balance, Blue Enable, DNR, Gamma, Baud Rate, Command Ack, Factory Reset** or **Splash Duration**.
4. Press the MENU button to return to the previous menu.

ISF Calibration

To be used by a Runco Service Technician or an ISF Certified personnel. **A pass code is required to access the ISF Calibration window.**

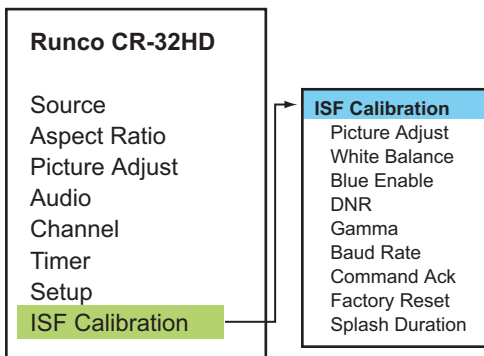

Picture Adjust

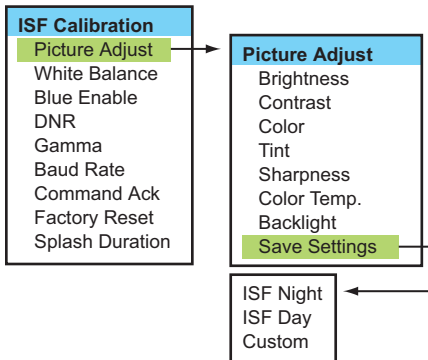

White Balance

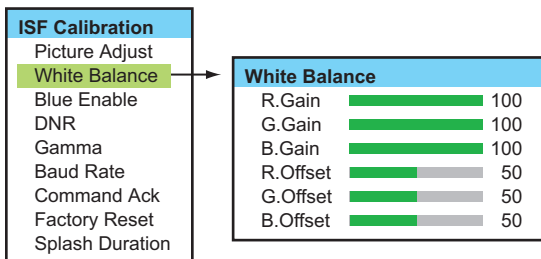

Note:

Any adjustments made in the White Balance menu will automatically be stored in the Custom menu location under Color Temp.

Blue Enable

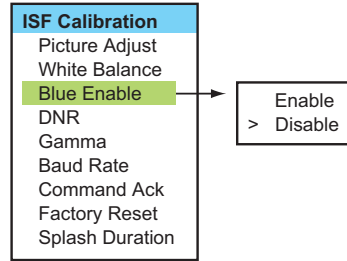

DNR (Digital Noise Reduction)

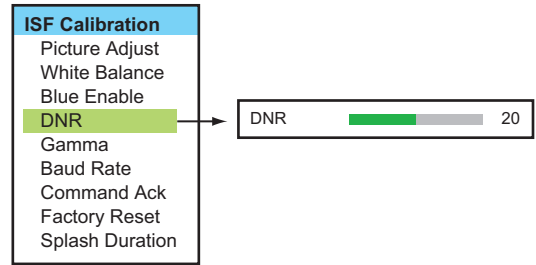

Gamma

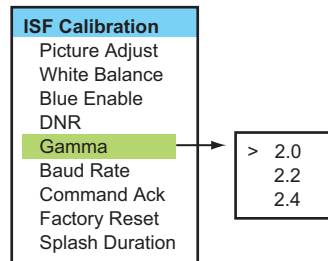

Baud Rate

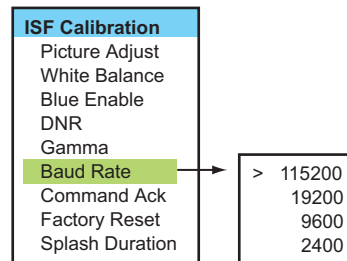

Command Ack

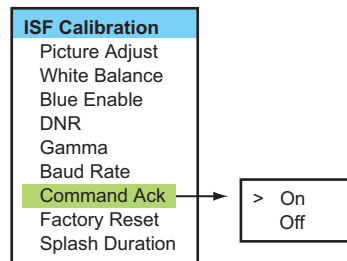

Factory Reset

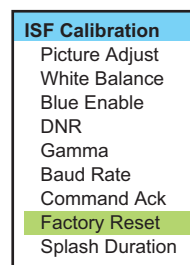

Splash Duration

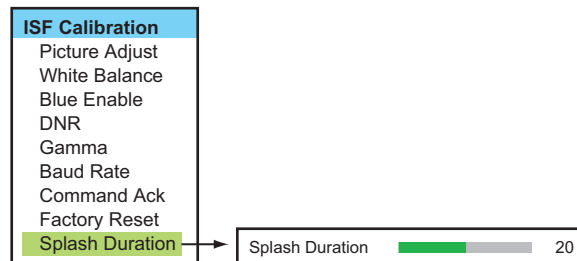

Picture in Picture (PIP)

1. Press the PIP () button.

There are 2 modes of PIP window : Small, Twin. Whenever you press this button, PIP window mode will be changed.

The PIP window are changed in the following order :

Small → Twin → Off

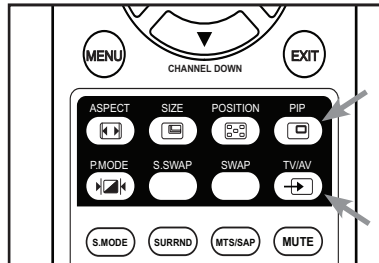

Displaying the Picture in Picture (PIP)

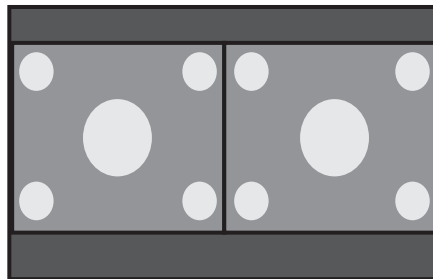
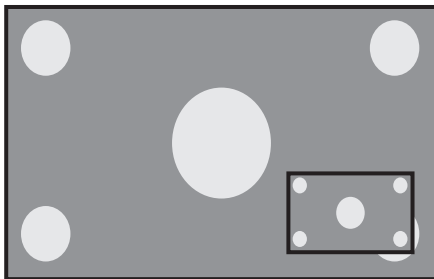

2. Press the () button to select the external signal source for the PIP.

- The external signal source will display whenever you press the () button.

(TV → VIDEO1 → VIDEO2 → VIDEO3 → VIDEO4 → DVI)

Note: You can change the main picture channel by pressing the () button.

Main \ PIP	TV	INPUT 1	INPUT 2	INPUT 3		INPUT 4		PC	
				VIDEO	COMPONENT	VIDEO	COMPONENT	RGB	DVI
TV	X	O	O	O	O	O	O	O	O
INPUT1	O	X	O	O	O	O	O	O	O
INPUT2	O	O	X	O	O	O	O	O	O
INPUT3	VIDEO	O	O	X	X	O	O	O	O
	COMPONENT	O	O	O	X	X	O	X	O
INPUT4	VIDEO	O	O	O	O	X	X	O	O
	COMPONENT	O	O	O	O	X	X	X	O
PC	RGB	O	O	O	O	X	O	X	X
	DVI	O	O	O	O	O	O	X	X

Changing the PIP Position

1. Press the  button on the remote control.
 - The PIP position will change among 4-positions whenever you press this button.

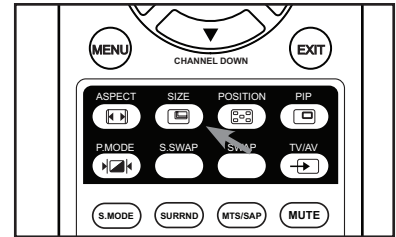
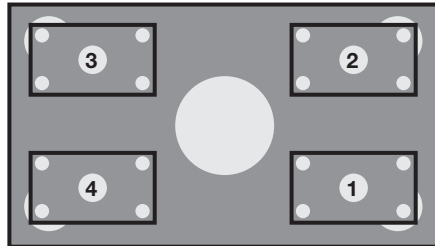

Changing the PIP Size

1. Press the  button on the remote control.
 - The PIP will change among 3 different sizes whenever you press this button.

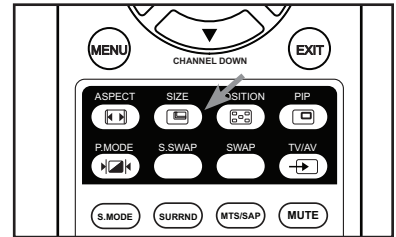
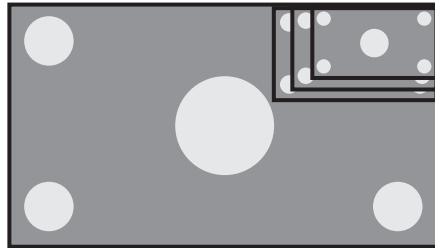

Selecting the Image Size in the PIP

1. Press the  button on the remote control.
 - When you are viewing the Sub-picture : The sub picture size will be changed in the following order whenever you press this button.

Standard 4:3 → Wide 16:9

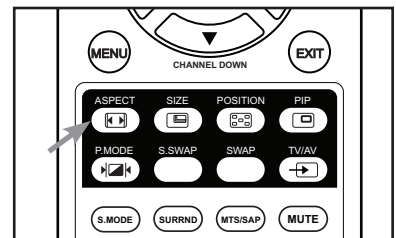

Selecting the Image Mode in the PIP

1. Press the  PIP picture mode button on the remote control.
 - The PIP picture mode will change between ISF Day to ISF Night when this button is pressed.

ISF Day → ISF Night

ISF Day: Select this mode when there is a lot of ambient light.

ISF Night: Select this mode when there is low ambient light or at night.

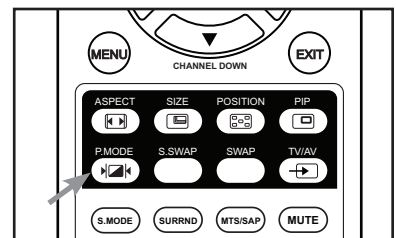

Note: Both the ISF Day and ISF Night memory can be customized in the ISF Calibration Menu for each input. (To be performed by a Certified Runco Technician)

1. Press the () button on the remote control.

- The Main image and PIP image will switch with each other whenever you press this button.

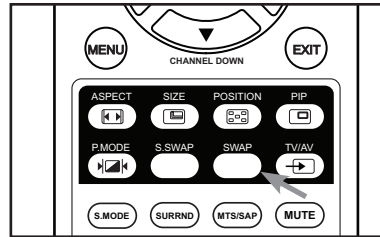

Swapping the Main & Sub-Picture

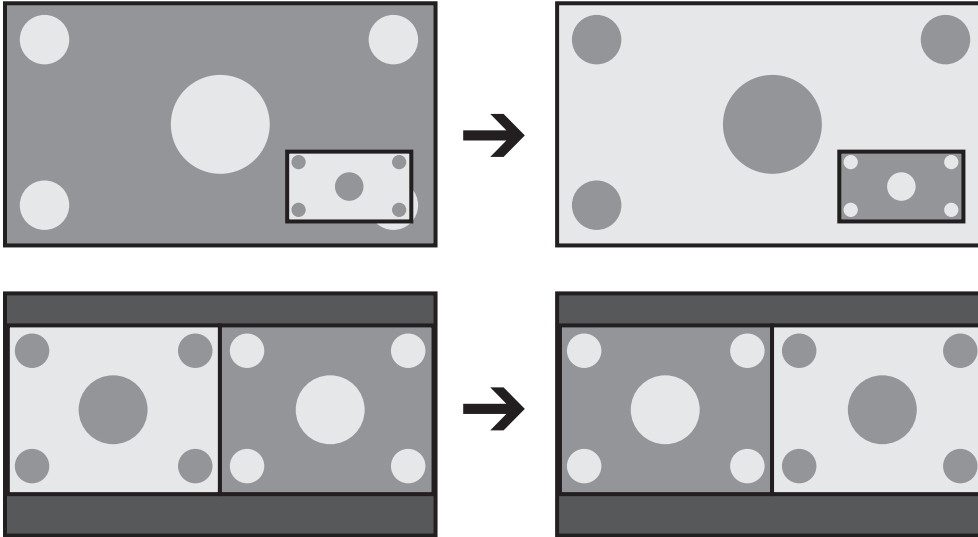

1. Press the () button on the remote control.

- The Main sound and PIP sound will switch with each other whenever you press this button.

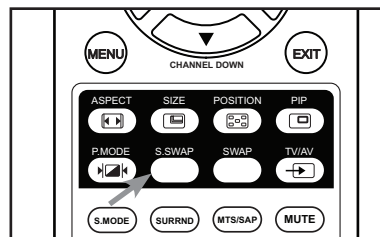

Swapping the Main & Sub-Sound

Changing the PIP Aspect Ratio

1. Press the  button on the remote control.
 - When you are viewing the Main image:
The image will change as shown below whenever you press this button.
Standard 4:3 → Wide 16:9

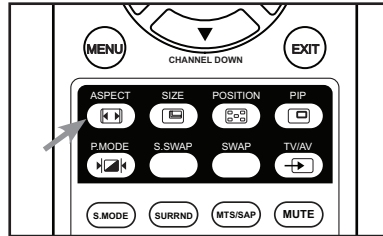

STANDARD 4:3 mode

The image is displayed at a Standard 4:3 aspect ratio. The input signal will be scaled to fit in the center of the 16:9 screen.

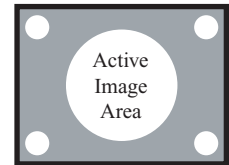

Wide 16:9 mode

The Wide 16:9 mode expands the image in the horizontal direction. The image is compressed vertically, but with anamorphic software the image will appear properly proportioned. This is best suited for use with 16:9 DVD's and HDTV.



Stereo Sound / SAP

Depending on the particular program being broadcast, you can listen to stereo, mono, or a Secondary Audio Program. (SAP audio usually a foreign-language translation. Sometimes SAP has unrelated information like news or weather.)

Listening to Stereo Sound / SAP

1. You can select sound options (**Mono**, **Stereo**, **SAP**, **Mono+ SAP**) depending on the broadcast signal by pressing the (MTS/SAP) button on the remote control.

- Choose **Stereo** for channels that are broadcasting in stereo.
- Choose **Mono** for channels that are broadcasting in mono, or if you are having difficulty receiving a stereo signal.
- Choose **SAP** to listen to the Secondary Audio Program, which is usually a foreign-language translation.

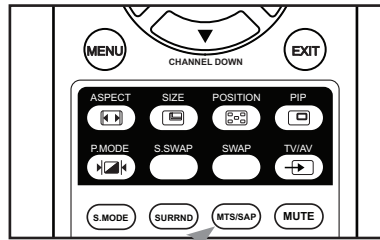

Option \ Broadcasting	M	S	SAP	M+SAP
M	M	M	M	M
S	M	S	M	S
M+SAP	M	M	SAP	M+SAP
S+SAP	M	S	SAP	M+SAP

S : Stereo

M : Mono

SAP : Secondary Audio Program

M + SAP : Mono + SAP

S + SAP : Stereo + SAP

RS-232 Configurations

RS-232C Configurations

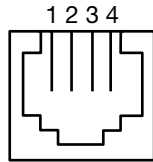

- Pin 1: Ground
- Pin 2: TxD
- Pin 3: Ground
- Pin 4: RxD

- Note:**
- All commands are in ASCII format
 - Default baud rate is 115200,8,N,1, but can be changed (see page 26)
 - No carriage return is necessary

For an added convenience, an RJ-11 to DB9 (Male) adaptor is provided but is not required. If the adaptor is used, use a null-modem cable.

The pin configuration on the adaptor is as follows:

No.	Pin Name	No.	Pin Name
1	No Connection	8	No connection
2	RXD (Receive data)	9	No Connection
3	TXD (Transmit data)		
4	No connection		
5	GND		
6	No connection		
7	No connection		

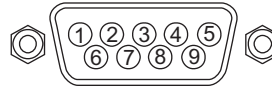

Command from host	'['	COMMAND (3 byte)	ARGUMENT (4 byte)
Ack from monitor	']'	RETURN (4 byte)	'\n'

Serial Protocol

'[' + 'S3A' + '000#' Set audio volume to ### (=000~100) <i>Example:</i> [S3A000075 sets volume to 75	'[' + 'S4G' + '000#' PIP Input selection 0=TV 1=Input1 2=Input2 3=Input3 4=Input4 5=DVI 6=RGB <i>Example:</i> [S4G0004 selects Input4
'[' + '+3A' Audio volume up	'[' + 'SAB' + '000#' Power on/off control 0=standby, 1=on <i>Example:</i> [SAB0001 turns unit on
'[' + '- 3A Audio volume down	'[' + 'SBA' + '000#' Picture mode selection 0=Custom 1=ISF Night 2=ISF Day <i>Example:</i> [SBA0001 selects ISF Night
'[' + 'S4A' + '000#' Main input selection 0=TV 1=Input1 2=Input2 3=Input3 4=Input4 5=DVI 6=RGB <i>Example:</i> [S4A0006 selects RGB	'[' + 'SCA' + '000#' Caption on/off 0=off 1=on <i>Example:</i> [SCA0000 turns caption off
'[' + 'S4E' + '000#' Aspect ratio selection 0=Standard (4x3) 1=VirtualWide 2=Letterbox 3=Anamorphic <i>Example:</i> [S4E0002 selects Letterbox	'[' + 'SCB' + '####' Set TV channel number 0012=AIR12 1012=CATV12 <i>Example:</i> [SCB0012 selects antenna Ch.12
'[' + 'S4F' + '0101' Select Composite Video for Input1 + '0102' Select S-Video for Input1 + '0201' Select Composite Video for Input2 + '0202' Select S-Video for Input2 + '0301' Select Composite Video for Input3 + '0303' Select Component Video for Input3 + '0401' Select Composite Video for Input4 + '0403' Select Component Video for Input4 <i>Example:</i> [S4F0101 selects Composite video for Input1	'[' + '+CB' TV channel up '[' + '-CB' TV channel down '[' + 'SCC' + '000#' Favorite channel selection 1=FC1 2=FC2 3=FC3 4=FC4 <i>Example:</i> [SCC0002 selects favorite channel 2
	'[' + 'SDA' + '000#' Set PIP mode 0=OFF 1=PIP 2=POP <i>Example:</i> [SDA0002 selects POP
	'[' + 'SDB' + '000#' Set PIP size 0=small 1=medium 2=large <i>Example:</i> [SDB0001 selects medium PIP size

The following serial commands are meant to emulate buttons on the remote control. Each button has its own serial command, so effectively it is as if you were using the IR remote only you'll be doing so via serial commands. Using these commands will provide active OSD responses just like the IR remote.

Each command begins with “[key]” (quotations are not part of the command), followed by the four-digit number of the button. No carriage return is necessary. The response you receive from the unit if the command is valid will be a close bracket followed by the four-digit numeric code you sent. **(Example: The ‘ON’ command is “[key0015]”, the response will be “[0015]”). All commands are in ASCII.**

‘[’ + ‘key’ + ‘000#’	Function	‘[’ + ‘key’ + ‘000#’	Function
‘[’ + ‘key’ + 0002	OFF	‘[’ + ‘key’ + 0007	RIGHT (Arrow Key)
‘[’ + ‘key’ + 0015	ON	‘[’ + ‘key’ + 0016	DOWN (Arrow Key)
‘[’ + ‘key’ + 0004	Number 1	‘[’ + ‘key’ + 0018	UP (Arrow Key)
‘[’ + ‘key’ + 0005	Number 2	‘[’ + ‘key’ + 0011	LEFT (Arrow Key)
‘[’ + ‘key’ + 0006	Number 3	‘[’ + ‘key’ + 0046	ENTER
‘[’ + ‘key’ + 0008	Number 4	‘[’ + ‘key’ + 0026	MENU
‘[’ + ‘key’ + 0009	Number 5	‘[’ + ‘key’ + 0100	EXIT
‘[’ + ‘key’ + 0010	Number 6	‘[’ + ‘key’ + 0063	ASPECT RATIO
‘[’ + ‘key’ + 0012	Number 7	‘[’ + ‘key’ + 0047	SIZE
‘[’ + ‘key’ + 0013	Number 8	‘[’ + ‘key’ + 0034	POSITION
‘[’ + ‘key’ + 0014	Number 9	‘[’ + ‘key’ + 0032	PIP
‘[’ + ‘key’ + 0017	Number 0	‘[’ + ‘key’ + 0037	P.MODE
‘[’ + ‘key’ + 0035	Number 100	‘[’ + ‘key’ + 0052	S.SWAP
‘[’ + ‘key’ + 0023	TIMER OFF	‘[’ + ‘key’ + 0033	SWAP
‘[’ + ‘key’ + 0105	INPUT1	‘[’ + ‘key’ + 0036	TV/AV
‘[’ + ‘key’ + 0027	INPUT2	‘[’ + ‘key’ + 0053	S.MODE
‘[’ + ‘key’ + 0028	INPUT3	‘[’ + ‘key’ + 0054	SURROUND
‘[’ + ‘key’ + 0001	INPUT4	‘[’ + ‘key’ + 0024	MTS/SAP
‘[’ + ‘key’ + 0102	DVI	‘[’ + ‘key’ + 0091	MUTE
‘[’ + ‘key’ + 0101	RGB HD	‘[’ + ‘key’ + 0057	FAVORITE CHANNEL 1
‘[’ + ‘key’ + 0019	TV	‘[’ + ‘key’ + 0045	FAVORITE CHANNEL 2
‘[’ + ‘key’ + 0003	CUSTOM	‘[’ + ‘key’ + 0044	FAVORITE CHANNEL 3
‘[’ + ‘key’ + 0062	ISF NIGHT	‘[’ + ‘key’ + 0055	FAVORITE CHANNEL 4
‘[’ + ‘key’ + 0031	ISF DAY		
‘[’ + ‘key’ + 0040	ANAMORPHIC		
‘[’ + ‘key’ + 0043	4X3		
‘[’ + ‘key’ + 0039	LETTERBOX		
‘[’ + ‘key’ + 0126	VIRTUALWIDE		

Signals Supported

If the signal from the system equals the standard signal mode, the screen will adjust automatically. If the signal from the system does not equal the standard signal, adjust the display mode as shown below referring to your video card instructions. Otherwise there may be no picture.

Standard Display Mode

	Mode		V.Freq (Hz)	H.Freq (KHz)
SD	720 x 240	60i	59.94	15.75
SD	720 x 480	60p	59.94	31.50
HD	1280 x 720	60p	60.00	44.90
HD	1920 x 1080	60i	60.00	33.70
VESA	720 x 400	85	85.00	37.90
VESA	720 x 350	85	85.00	37.90
IBM	720 x 400	70	70.10	31.50
IBM	720 x 350	70	70.10	31.50
VESA	720 x 480	60	59.94	31.50
MAC	720 x 480	67	66.70	35.00
VESA	720 x 480	72	72.80	37.80
VESA	720 x 480	75	75.00	37.50
VESA	720 x 480	85	85.00	43.60
VESA	800 x 600	56	56.25	35.20
VESA	800 x 600	60	60.30	37.90
VESA	800 x 600	72	72.20	48.70
VESA	800 x 600	75	75.00	46.90
VESA	800 x 600	85	85.10	53.70
MAC	832 x 624	75	74.50	49.70
VESA	1024 x 768	60	60.00	48.40
MAC	1024 x 768	60	60.00	48.70
VESA	1024 x 768	70	70.10	56.50
IBM	1024 x 768	72	72.10	57.50
VESA	1024 x 768	75	75.00	60.00
MAC	1024 x 768	75	75.00	60.00
VESA	1024 x 768	85	85.00	68.70

Pin Configuration (PC/DVI)

PC Input Connector (D-Sub 15Pin)

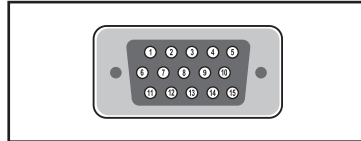

Pin	PC IN	Pin	PC IN
1	Red (R)	8	Blue (B) Ground
2	Green (G)	9	Reserved
3	Blue (B)	10	Sync Ground
4	Ground	11	Ground
5	Ground (DDC)	12	Data (DDC)
6	Red (R) Ground	13	Horizontal Sync
7	Green (G) Ground	14	Vertical Sync
		15	Clock (DDC)

DVI-D Connector

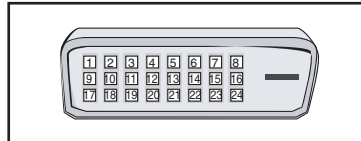

Pin	Signal Assignment	Pin	Signal Assignment
1	T.M.D.S. Data2-	13	T.M.D.S. Data3+
2	T.M.D.S. Data2+	14	+5V Power
3	T.M.D.S. Data2/4 Shield	15	Ground (for +5V)
4	T.M.D.S. Data4-	16	Hot Plug Detect
5	T.M.D.S. Data4+	17	T.M.D.S. Data0-
6	DDC Clock	18	T.M.D.S. Data0+
7	DDC Data	19	T.M.D.S. Data0/5 Shield
8	No Connect	20	T.M.D.S. Data5-
9	T.M.D.S. Data1-	21	T.M.D.S. Data5+
10	T.M.D.S. Data1+	22	T.M.D.S. Clock Shield
11	T.M.D.S. Data1/3 Shield	23	T.M.D.S. Clock+
12	T.M.D.S. Data3-	24	T.M.D.S. Clock-

Troubleshooting

No picture or sound.	<ul style="list-style-type: none"> • Make sure the display is plugged in. • Make sure the power cord is connected correctly. • Check for power failure.
Screen is black.	<ul style="list-style-type: none"> • Make sure the correct source is selected. • Press the TV/AV button to change to TV.
Picture is OK but there is no sound.	<ul style="list-style-type: none"> • Press the Mute button. • Check another channel. • Increase the volume.
Poor sound quality.	<ul style="list-style-type: none"> • Make sure the channel is using a stereo broadcast by pressing the display (MUSIC) button. • Select Mono. The sound quality of a stereo broadcast may be unstable in an area with a weak signal. (See page 31)
No image on a specific channel. (For CR-32HD only)	<ul style="list-style-type: none"> • Make sure the channel selection is correct. • Change the antenna direction to the right or left. • Adjust the fine tuning of the channel.
Image is not stable and may appear to vibrate, horizontal bars appear.	<ul style="list-style-type: none"> • Adjust the fine tuning of the channel. • Make sure there is no powerful electromagnetic wave interference from the transmitting station. • Stop using a hair drier, electric drill or electric blender.
No color on a specific channel (a black & white image).	<ul style="list-style-type: none"> • Check other channels to see if the specific channel is broadcasting a black & white program. • Adjust the color. (See page 19)
Black or white dots appear on all channels or a specific channel. (For CR-32HD only)	<ul style="list-style-type: none"> • Make sure the antenna is connected correctly. (See page 13) • Make sure the antenna or wire connection is good. • Adjust the fine tuning of the channel.

For Display Panel

For Monitor

“No signal” message	<ul style="list-style-type: none"> • Check if the signal cable (DVI Cable) is properly connected to the computer. (See page 15)
“Out of range” message	<ul style="list-style-type: none"> • This message may appear when the resolution and frequency of the video card in the computer are out the range of the display. Select the proper resolution and frequency for the display. (See page 35)
Picture rolls down vertically.	<ul style="list-style-type: none"> • Check if the signal cable (DVI Cable) is properly connected to the computer. (See page 15)
A shadowed area appears on the screen.	<ul style="list-style-type: none"> • Make sure the resolution and frequency of the computer video card are set properly to the range of the display. Set the picture again referring to the standard display mode and current mode. (See page 35)
The image is too large or too small.	<ul style="list-style-type: none"> • Adjust the size/position of the image. (See page 22 or 24)
Horizontal or vertical bars appear on the screen.	<ul style="list-style-type: none"> • Adjust the frequency and fine tuning. • Adjust the resolution and frequency to the recommended specifications. (See page 35) (1024 x 768 @ 60Hz)
The power indicator light blinks green.	<ul style="list-style-type: none"> • The display is in power saving mode, as it is not receiving a signal from the computer. The picture will return to normal status when you press any key on the keyboard or move the mouse.

Specifications

	CR-32HD	CR-40HD
Native Resolution:	1366 x 768 WXGA	1366 x 768 WXGA
Screen Size:	32 in. (diagonal)	40 in. (diagonal)
Screen Aspect Ratio:	16:9	16:9
Available Aspect Ratios:	4:3, Letterbox, 16:9 Anamorphic, VirtualWide™	4:3, Letterbox, 16:9 Anamorphic, VirtualWide™
DTV Compatibility:	480p, 720p, 1080i	480p, 720p, 1080i
ISF Settings:	Yes	Yes
Contrast Ratio:	1000:1	800:1
Data/Graphics Compatibility:	Up to 1024 x 768	Up to 1024 x 768
Vivix Processing:	3:2 pull down	3:2 pull down
Inputs:	Multiple input combinations with up to (4) Composite, (2) S-Video, (2) Component, (1) DVI w/HDCP, (1) RGB (15-pin mini D-sub), (1) RS-232, (4) Audio (stereo RCA pairs), (1) RF Antenna	Multiple input combinations with up to (4) Composite, (2) S-Video, (2) Component, (1) DVI w/HDCP, (1) RGB (15-pin mini D-sub), (1) RS-232, (4) Audio (stereo RCA pairs)
Outputs:	(1) Composite, (1) Audio (stereo RCA pair)	(1) Composite, (1) Audio (stereo RCA pair)
Audio System:	10W RMS x 2, L/R two-way Detachable Speaker System	10W RMS x 2, L/R two-way Detachable Speaker System
Tuner:	185 CH. NTSC Stereo (PAL as monitor only) HDTV Ready, PIP/POP, V-chip, Closed Caption	Not available
Discrete IR Control:	Source, power and aspect ratios	Source, power and aspect ratios
Power Requirements:	100-240V AC, 50/60Hz	100-240V AC, 50/60Hz
Power Consumption:	180W	280W
Operating Environment:	40 to 95°F (5 to 35°C); 20-80% humidity (non-condensing)	40 to 95°F (5 to 35°C); 20-80% humidity (non-condensing)
Dimensions:	Width: 31 3/8 in. (797 mm) Width w/speakers: 38 1/8 in. (968 mm) Depth: 4 1/2 in. (114 mm) Depth w/stand: 9 27/32 in. (250 mm) Height: 19 1/2 in. (495 mm) Height w/stand: 21 3/4 in. (552 mm) Weight w/stand: 50.71 lbs. (23 kg)	Width: 39 in. (991 mm) Width w/speakers: 45 3/4 in. (1162 mm) Depth: 4 1/2 in. (114 mm) Depth w/stand: 9 27/32 in. (250 mm) Height: 23 1/2 in. (597 mm) Height w/stand: 25 1/8 in. (638 mm) Weight w/stand: 68.34 lbs. (31 kg)
Regulatory Approvals:	Complies with FCC, CE, C-Tick	Complies with FCC, CE, C-Tick
Limited Warranty:	(1) One year parts and labor from the date of delivery to the end user.	(1) One year parts and labor from the date of delivery to the end user.

Dimensions

CR-32HD

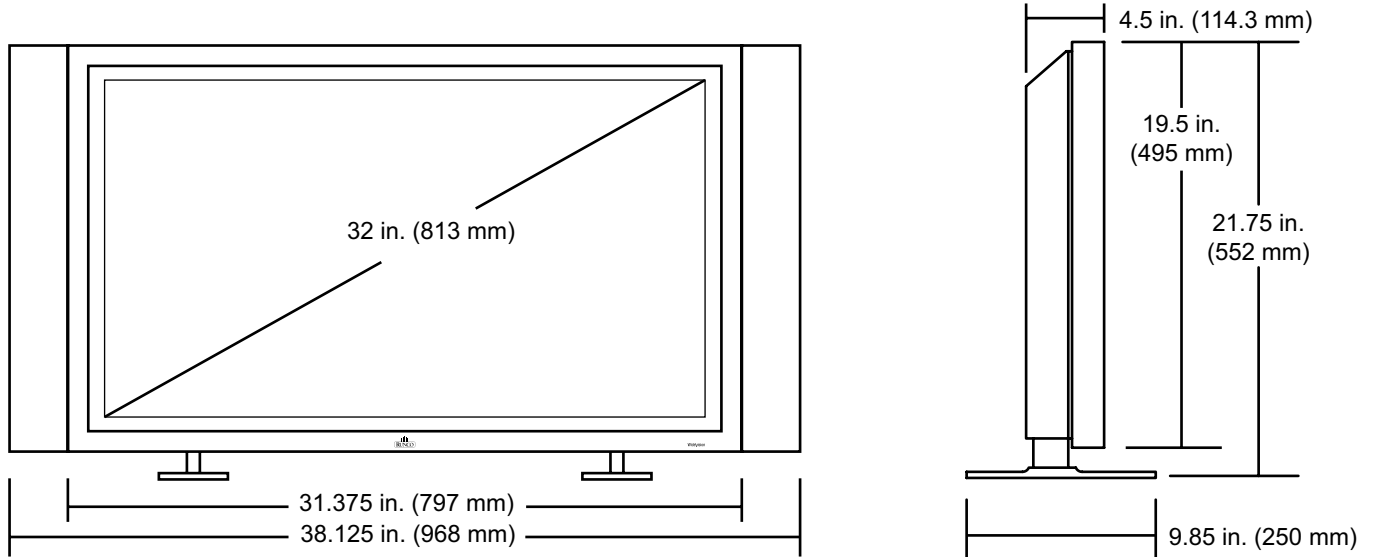

CR-40HD

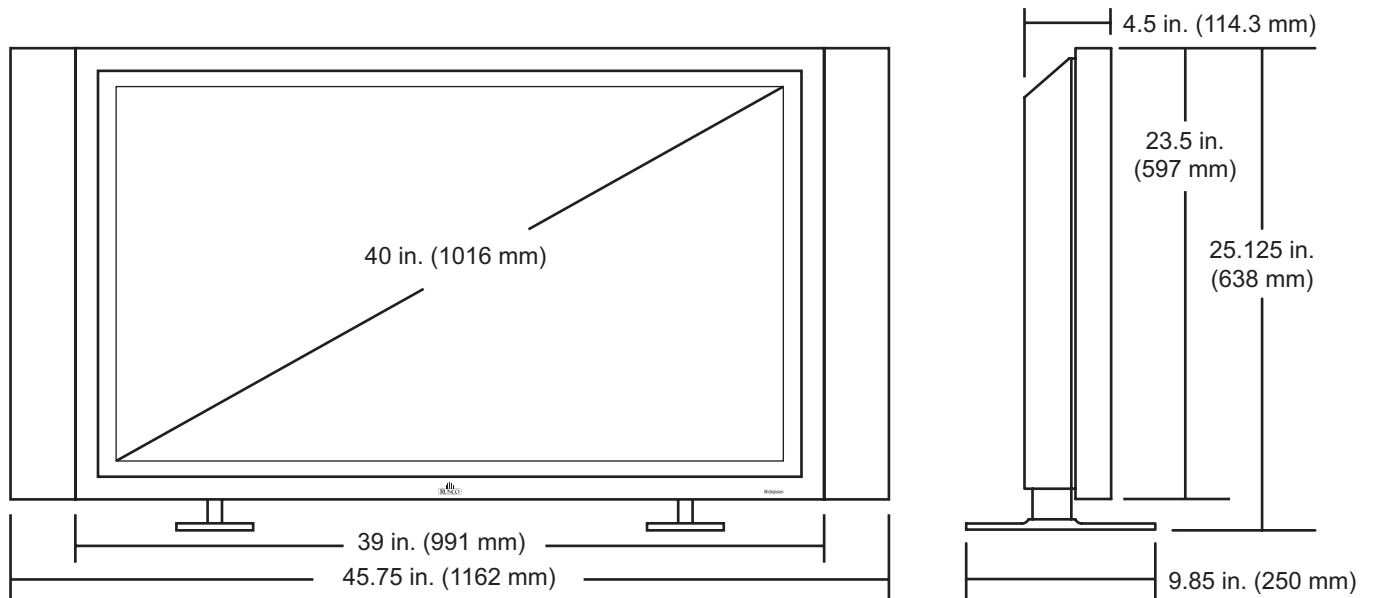



SERIAL NUMBER

RUMA-011095

7-13-05